

Complex Aerohydrodynamic Research and the Effectiveness of Arresting Dispersed Particles for Barbotage-Rotation

A. K. Panov,¹ R. R. Usmanova,¹ V. G. Zaikov,² G. E. Zaikov²

¹Branch UGNTU, 2 Oktyabrya bevd., Sterlitamak 453118, Bashkortostan, Russia

²N.M. Emanuel Institute of Biochemical Physics, RAN, 4 Kosygin Street, Moscow 119991, Russia

Received 14 March 2006; accepted 11 July 2006

DOI 10.1002/app.25318

Published online 5 February 2007 in Wiley InterScience (www.interscience.wiley.com).

ABSTRACT: The design of barbotage-rotation installation with different profiles of blades of the rotator has been created on the basis of modeling method. As a result of the complex of aerohydrodynamic research in the system "gas-liquid" carried out on the barbotage-rotation unit, certain recommendations on the improvement of the construction and operating conditions have been devel-

oped with a view to a rise in the effectiveness of dust removal. © 2007 Wiley Periodicals, Inc. *J Appl Polym Sci* 104: 2088–2091, 2007

Key words: aerohydrodynamic; dispersed particles; barbotage-rotation; gas liquid; design; profiles of blades

INTRODUCTION

Barbotage-rotation installations designed for clearing and cooling gas discharges are applied in chemical, oil refining, and other fields of industry. These units are important in solving ecological problems, e.g., the refining process of waist (exhaust) gas removed from the unit into the atmosphere.¹ That is why research on the improvement of the design and operating conditions of barbotage-rotation units has always been urgent and remains problem of today.²

With a view to the intensification of the refining process and a rise in the effectiveness of the barbotage-rotation unit, a complex of aerohydrodynamic research on the improvement of the construction of the rotator and operating conditions of the unit has been carried out.

DESCRIPTION OF THE UNIT FOR DUST REMOVAL PROCESS RESEARCH AND THE TECHNIQUE (METHOD) OF THE EXPERIMENT

Research on aerohydrodynamics of curled (rotated) flows and the effectiveness of dust removal in the system "gas-liquid" was carried out on the barbotage-rotation unit with different profiles of blades of the rotators. The unit was designed taking into consideration the possible approximations to real conditions of industrial installations (Fig. 1).

It was taken into account that the rotator should ensure not only a high degree of dust removal but

be constructively well coordinated with the barbotage-rotation device.

Air and white soot (smoke-white) with the particle size of $d = 2\text{--}40$ mkm were used as a model system.

Atmospheric air forced by ventilator 2 (VC 1446, producer being Industrial Ventilation, Sterlitamak, Bashkortostan) was passed through electric heater 3 at the required heat temperature (100°C). Dusty air rate of flow $G = (0.6\text{--}4.0) 10^{-2} \text{ m}^3/\text{s}$. After reaching the operating temperature conditions and sprayers 5, placed in front of and behind the rotator, the flow was given reflux liquid, reflux feed being regulated by rotameter RS-7. Simultaneously the flow was given white soot from feed bunker 6. While the dusty air was passing through the blade rotator, in the field of centrifugal forces, dust removal and cooling of the gas flow took place. The unremoved dispersed particles of the flow fell out in filter 11. The removal of the sludge and dispersed particles was carried out through unions in the bottom of the device.

The purified air was discharged into the atmosphere. Sprayers 5 were placed in front of and behind the atmosphere rotator for the improvement of purifying conditions. Reflux feeding was regulated by rotameter RS-7 ($Q = (5.5\text{--}14) \times 10^{-4} \text{ m}^3/\text{s}$). The liquid reflux favored the enlargement of the unremoved, dispersed particles and the reduction of time of removal. The sludge formed was washed off with the liquid sprayed by the sprayer placed behind the rotator and discharged into the sludge-collector.

The subject of the Research was constructions of rotators with four kinds of profiles of blades: parabolic, hyperbolic, sine wave, and direct (Fig. 2).

Correspondence to: G. E. Zaikov (chembio@sky.chph.ras.ru).

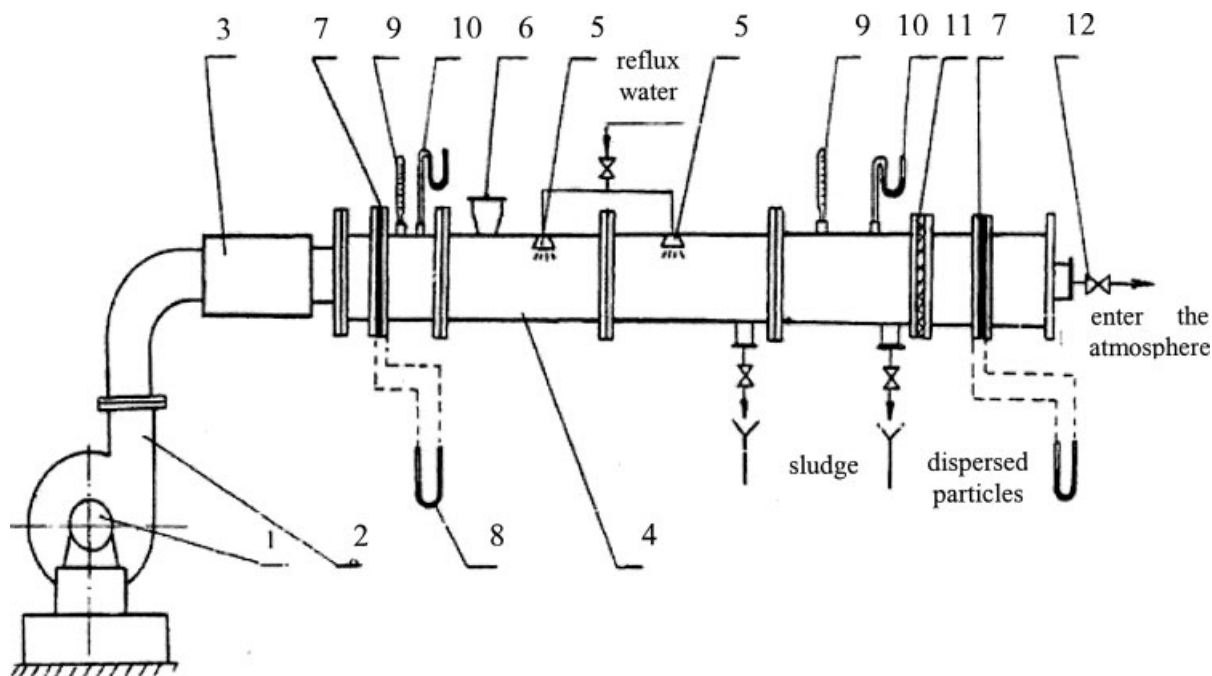

Figure 1 Flow diagram of the experimental unit: 1 – electric motor; 2 – ventilator (fan); 3 – electric heater; 4 – rotation chamber (cell); 5 – sprayers; 6 – bunker; 7 – diaphragm; 8 – pressure-gauge; 9 – thermometer; 10 – manometer; 11 – filter; 12 – valve.

EVALUATION OF THE EFFECTIVENESS OF DUST REMOVAL

Full (complete) effectiveness of dust removal was (calculated) expressed in percentage³ as a ratio between mass of removed dust and mass of initial dust.

$$\eta = \frac{C_n - C_k}{C_n} = \frac{C_{rem}}{C_n} \times 100\%, \quad (1)$$

where C_n – mass expenditure of rigid particles on exit, kg/s; C_{rem} – mass expenditure of removed particles, kg/s.

According to the results of the effectiveness accounts there were built diagrams for different profiles of blades of the rotator. As the data obtained shows for the models of blades of the rotator being under research the main mass of particles is removed completely. The effectiveness of dust removal remains within 85–99%. With high reflux common efficiency of the device rises (Fig. 3). With minimum reflux of $Q = 8.5 \times 10^{-4} \text{ m}^3/\text{s}$, common efficiency comes to 85%.

The data obtained shows that even with little reflux a high degree of dust removal is obtained. Research shows that in the investigated range the initial dust concentration practically does not influence the effectiveness of dust removal. This is of great importance for the device work in industrial service conditions where the dust content being the function

of the technological process conditions may vary over a wide range.

With high air expenditure the device efficiency falls (drops) (Fig. 4). This can be explained by the fact that at significant air expenditure and little water expenditure some rigid particles have no time to enter the contact with the liquid and are discharged from the device.

In the diagram, points (dots) show experimental efficiency values and continuous lines show theoretical values calculated by formula (1). It is interesting to note that the least dust removal efficiency is obtained

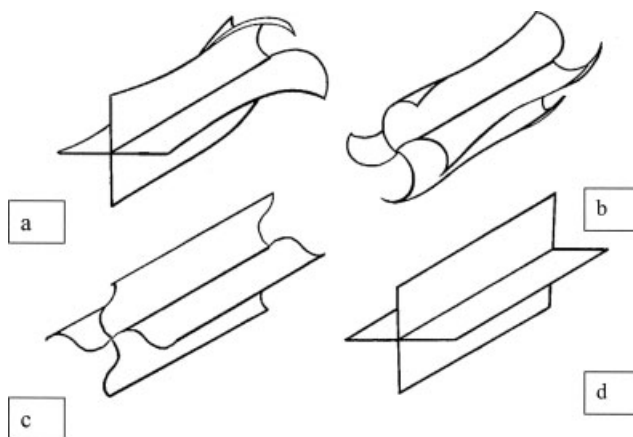

Figure 2 Profiles of blades of rotators: a – parabolic; b – hyperbolic; c – sine wave; d – direct.

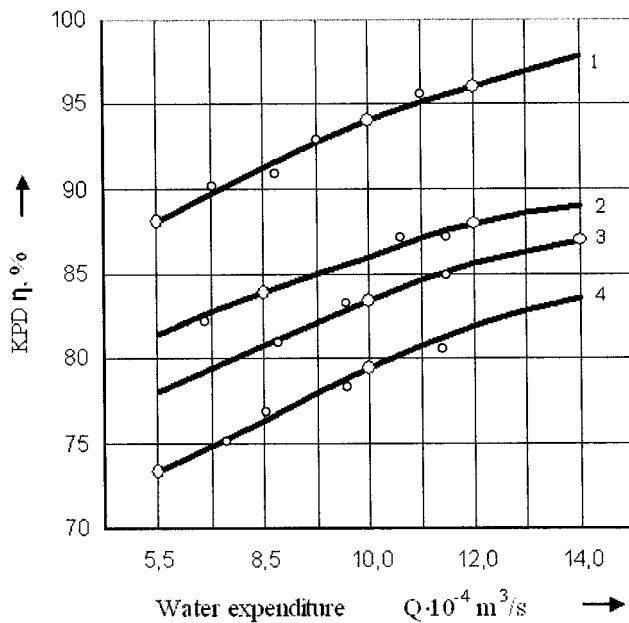

Figure 3 Dependence of the device efficiency on water expenditure at constant air expenditure ($G = 40 \times 10^{-3} \text{ m}^3/\text{s}$) for different profiles of the rotator blades. 1 – parabolic; 2 – hyperbolic; 3 – sine wave; 4 – direct.

for rectangular profile of blades, coming to 85%. The highest device efficiency (up to 99%) is obtained for parabolic profile of rotator blades.

AEROHYDRODYNAMIC RESEARCH RESULTS FOR BARBOTAGE-ROTATION DEVICE IN COMPARISON WITH THEORETICAL ONES

There is a general tendency to a rise in hydrolic resistance with high speed in a free cut. The maximum value of hydrolic resistance at specific reflux of $Q = 14 \times 10^{-4} \text{ m}^3/\text{s}$ comes to $\Delta P = 30\pi a$ for hydrolic profile of blades, $\Delta P = 20\pi a$ for direct and sine wave ones.

Thus constructive modifications of the profiles of the rotator blades enable one to raise significantly dust removal effectiveness (Figs. 3 and 4) with slight (small) hydrolic resistance increase.

Curling efficiency of rotator K varies from 0.2–1.0. The experimental data analysis shows that hydrolic resistance efficiency ξ at some K value does not depend on liquid expenditure, which is explained by two factors connected with reflux feeding of the device.

On the one hand reduction of ξ is observed because of gas tangential speed drop on the account of brake action of the liquid, on the other hand increase of ξ is connected with a rise in gas flow pressure on the liquid carrier.

On this foundation ξ account technique was developed, including ξ account formula for the “dry” device

$$\xi_{\text{dry}} = \frac{1}{n} \left(\left(\frac{R}{r} \right)^{2n} - 1 \right) + \frac{1}{K^2} \left(\frac{V_2}{V_1} \right)^2, \quad (2)$$

the formula of loss account of gas pressure on the liquid carrier

$$\xi_{\text{tr}} = 4 \left(\frac{Q}{G} \right)^{0.6} \sqrt{1 + \frac{1}{K^2}}, \quad (3)$$

and the final formula for ξ account of the reflux fed rotation device

$$\xi_{\text{sp}} = \frac{1}{n} \left(\left(\frac{R}{r} \right)^{2n} - 1 \right) + \frac{E^2}{K^2} \left(1 + \frac{\rho_l}{\rho_g} \right) \times \left(\frac{V_2}{V_1} \right)^2 + 4 \left(\frac{Q}{G} \right)^{0.6} \sqrt{1 + \frac{1}{K^2}}, \quad (4)$$

taking into consideration the presence of a disperse phase and partial loss of the flow curling. The ξ accounts, by this formula, will be well coordinated with the experiment data (Fig. 5).

In the diagram theoretical values of ξ are marked by a continuous line and the experiment data is marked by points (dots). The relative divergence of theoretical values calculated by formula (4) and the experimental data made no more than 15%.

Thus the technique offered with an adequate accuracy of accounts can be recommended for aerohydrodynamic research of the flows in the barbotage-

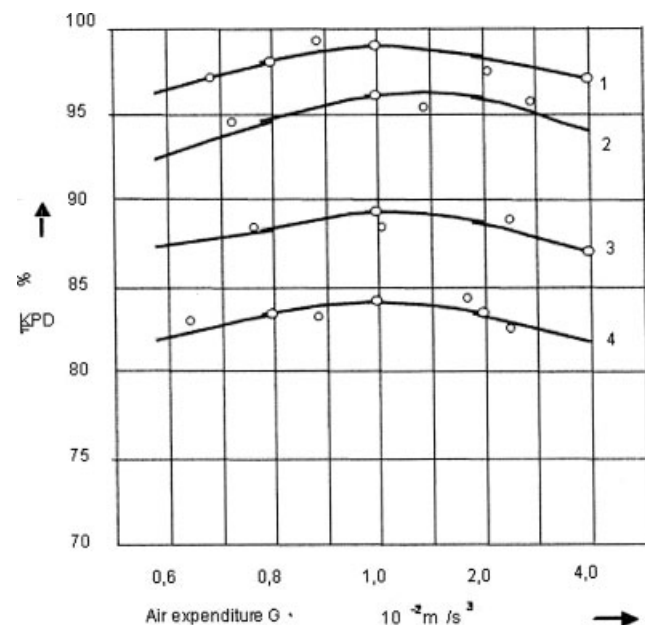

Figure 4 Dependence of the device efficiency on air expenditure at constant water expenditure ($Q = 8.5 \times 10^{-3} \text{ m}^3/\text{s}$) for different profiles of the rotator blades. 1 – parabolic; 2 – hyperbolic; 3 – sine wave; 4 – direct.

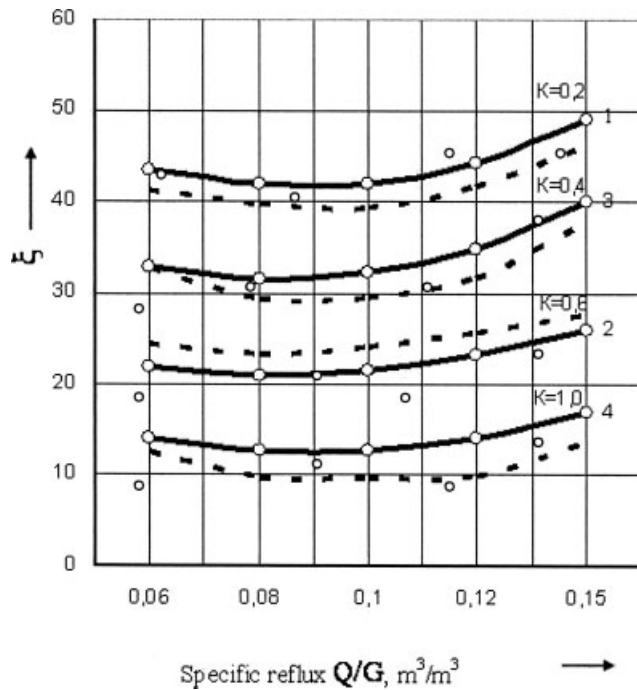

Figure 5 ξ dependence on specific reflux of the device with different values of curling efficiency.

rotation device with different constructive parameters of the rotator.

CONCLUSIONS

1. Taking into consideration the research results on dust removal from gas, it is advisable (expedient)

in what follows to use the barbotage-rotation device with parabolic profiles of rotator blades, having high effectiveness of dust removal (up to 99%) and small hydrolic resistance, as an optimum variant in dust removal system.

2. The introduction of barbotage-rotation device with parabolic profile of rotator blades is offered to Bashcortostan refinery plants for dust removal and cooling gas discharges.

NOMENCLATURE

E	Loss efficiency of curling
G	Gas expenditure, m^3/s
K	Curling efficiency, $k = (0.2-1.0)$
n	Experiment constant
P_g	Gas density, kg/m^3
P_l	Liquid density, kg/m^3
Q	Liquid expenditure, m^3/s
R	Apparatos radius, m
r	Rotation radius, m
V_1	Gas speed on inlet, m/s
V_2	Gas speed on inlet, m/s

References

1. Panov, A. K.; Usmanova, R. R.; Titov V. M.; Minsker K. S.; Zai-kov, G. E. Patent 2182843 RF MKI V 01 D 47/06 (2002).
2. Panov, A. K.; Usmanova, R. R.; Minsker, K. S. Chem Industry 2003, 4, 19.
3. Ugov, V. N.; Valdberg, A. J. Preparation of Industrial Gases for Clearing (in Russian); Khimia (Chemistry) Publishers: Moscow, 1985; p 206.